

INELS®

Lighting Control

for any space, offering comfort, energy savings, and ambiance.



www.inels.com

Lighting Control

Intelligent Solutions for Every Space

The iNELS lighting control system offers an advanced solution for managing lighting in various environments. It seamlessly integrates into homes, offices, and hospitality venues, ensuring optimal comfort and energy efficiency. This intelligent system allows users to control lighting with ease, creating tailored atmospheres for different activities and occasions.



1. Energy Efficiency

iNELS offers intelligent lighting management that automatically optimizes energy consumption, leading to savings on electricity bills. Customers can feel good about saving money while being environmentally friendly.



3. Flexible Control

Customers will appreciate the ability to easily control lighting from various locations using touch panels, mobile apps, or remote controls, enhancing convenience and user experience.



2. Pre-set Scenes

The option to set different lighting scenarios (e.g., "movie," "dinner," "work") allows users to quickly switch between atmospheres tailored to their activities, making it user-friendly.



4. Automation

Lighting automation uses motion sensors to activate lights based on presence and light intensity sensors for daylight harvesting, optimizing energy efficiency, enhancing comfort, and promoting sustainability in residential and commercial spaces.

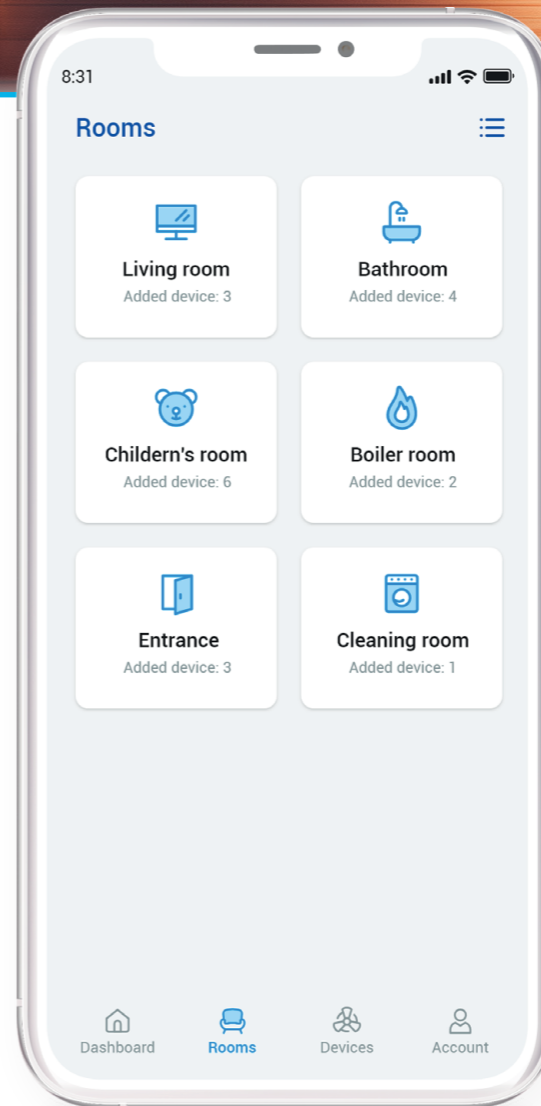

5. Universal load types

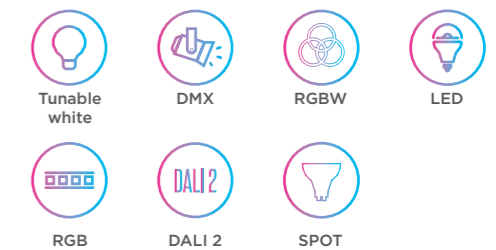

6. App control

The iNELS app allows users to easily control their lighting via smartphone or tablet. Users can adjust brightness, set automated scenes and schedules, or switch between lighting modes. The app ensures comfort and energy savings through remote access, optimizing lighting efficiency while enhancing the ambiance of any space.

Lighting Control

with iNELS BUS System

With the iNELS system, you can easily set lighting schedules, dim various lights according to the environment, and create custom lighting scenes, such as for relaxation or work. The system integrates multiple lighting types, from traditional bulbs to LED and modern DALI systems, ensuring maximum flexibility and energy savings.



Living Spaces

The iNELS system allows home owners to create customizable lighting that enhances atmosphere. For instance, a “Movie” scene can dim lights and set specific colors for a cozy environment, adding comfort while improving energy efficiency.

Hospitality Spaces

Hotels and restaurants benefit from setting the right atmosphere throughout the day. A “Welcome” scene can softly light the reception for arriving guests, while a “Dinner” scene creates an intimate dining experience. This flexibility enhances guest comfort and operational efficiency.



Office Environments

iNELS lighting enhances office productivity with Human-centric lighting, which supports well-being by mimicking natural light cycles, while energy-efficient controls intelligently manage resources, creating a dynamic, sustainable, and comfortable workplace environment.



Home Use

Tailored Lighting for Everyday Comfort

Lighting that adapts to your daily needs. Set up different scenes for relaxation, work, or entertainment, and enjoy comfort with energy savings.



Commercial Use

For large, versatile spaces

Perfect for offices, hotels, or retail spaces. Easy control of multiple lighting zones increases efficiency and adapts to any situation.



Basic Controls

ON/OFF switching for standard lighting. Dimming control for mood and ambiance settings.



Scene Creation

Predefined scenes for activities like "Relax," "Reading," or "Movie Night." Customizable via the iNELS app or wall panels.



Automated Lighting

Motion-based activation in hallways, bathrooms, or staircases. Time-scheduled lighting for morning wake-up or evening relaxation.



Human centric lighting

Light intensity sensors adjust artificial lighting based on natural light availability. Control color-changing RGB or tunable white lights for personalized lighting.



Voice Control

Integration with voice assistants (Google Assistant, Alexa) for hands-free operation.



Centralized Control

Unified control of all lighting systems across a building or complex. Integration with Building Management Systems (BMS) via MQTT or Modbus.

What You Need

for a Smart Lighting System

To create a smart lighting system with the iNELS BUS system, you need several key components that provide full control over lighting in your home or commercial space. This technology allows you to adjust brightness, color, and lighting scenes to suit your preferences. Let's explore what you will need to install and operate this system.

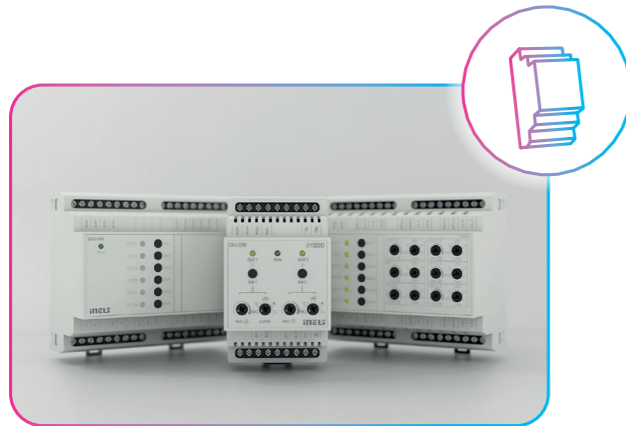

Actuators

The device that controls your lights, turning them on/off or dimming them as needed.



Detectors

Automate your lighting with motion or daylight sensors that adjust lights based on activity or natural light levels.



Controllers

Your control interface - simple to use and stylish, these panels let you control your lights and set scenes.



Gateways

Heart of the system - this central unit manages all the connected devices.

iNELS Home Control App

Allows you to manage lighting from anywhere using your smartphone or tablet.

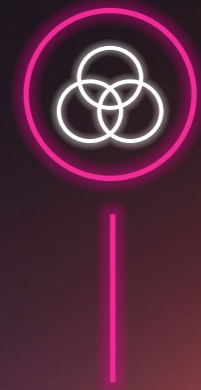

For more information
visit our website

www.inels.com

Lighting actuators

Precise Light Control

Take control of your lighting with iNELS actuators and detectors designed for precision and flexibility. From Zero crossing relays, universal dimmers to 0-10V systems or dynamic DALI setups, our devices ensure seamless operation. Customize your space and mood with wired and wireless dimming controllers.



Switching with Zero crossing

Handles High-Inrush Loads and prevent voltage surges. Ideal for LEDs and other sensitive lighting technologies:

- RFSAI-61B-SL/RFSAI-62B-SL:** Compact 1/2-channel wireless switch units for precise ON/OFF control of lighting systems.
- SA3-014M:** A versatile 14-channel switching actuator, perfect for managing multiple lighting circuits in complex installations,
- RC3-610M/DALI:** A room controller combining 8 relay channels and a DALI dimmer.

0-10V

0-10V Control

Perfect for analog lighting systems with smooth dimming transitions

- RFDAC-71B:** Compact analog controller for wireless applications.
- DAC3-04M:** Reliable wired digital-to-analog converter.
- RFDA-73M/RGB:** Wireless LED dimmer for RGB strips.
- DA3-03M/RGBW:** Wired dimming actuator for precise RGBW lighting



Phase Dimmer

Control any lighting type with precision and ease:

- RFDEL-71B-SL / RFDEL-71M:** 1-channel universal dimmers for flexible mounting options.
- RFDEL-76M:** Multi-channel wireless control with 6 outputs, ideal for larger installations.
- DA3-22M/DA3-66M:** Advanced dimming actuators for robust wired solutions.

DALI

DALI Control

Smart lighting control for scalable projects

- RFDALI-32B-SL/RFDALI-04B-SL:** Wireless DALI controllers for up to 32/4 addresses.
- CU3-09M/DALI:** Central unit combining BUS and DALI protocols.
- RC3-610M/DALI:** Room controller with integrated DALI dimmer.

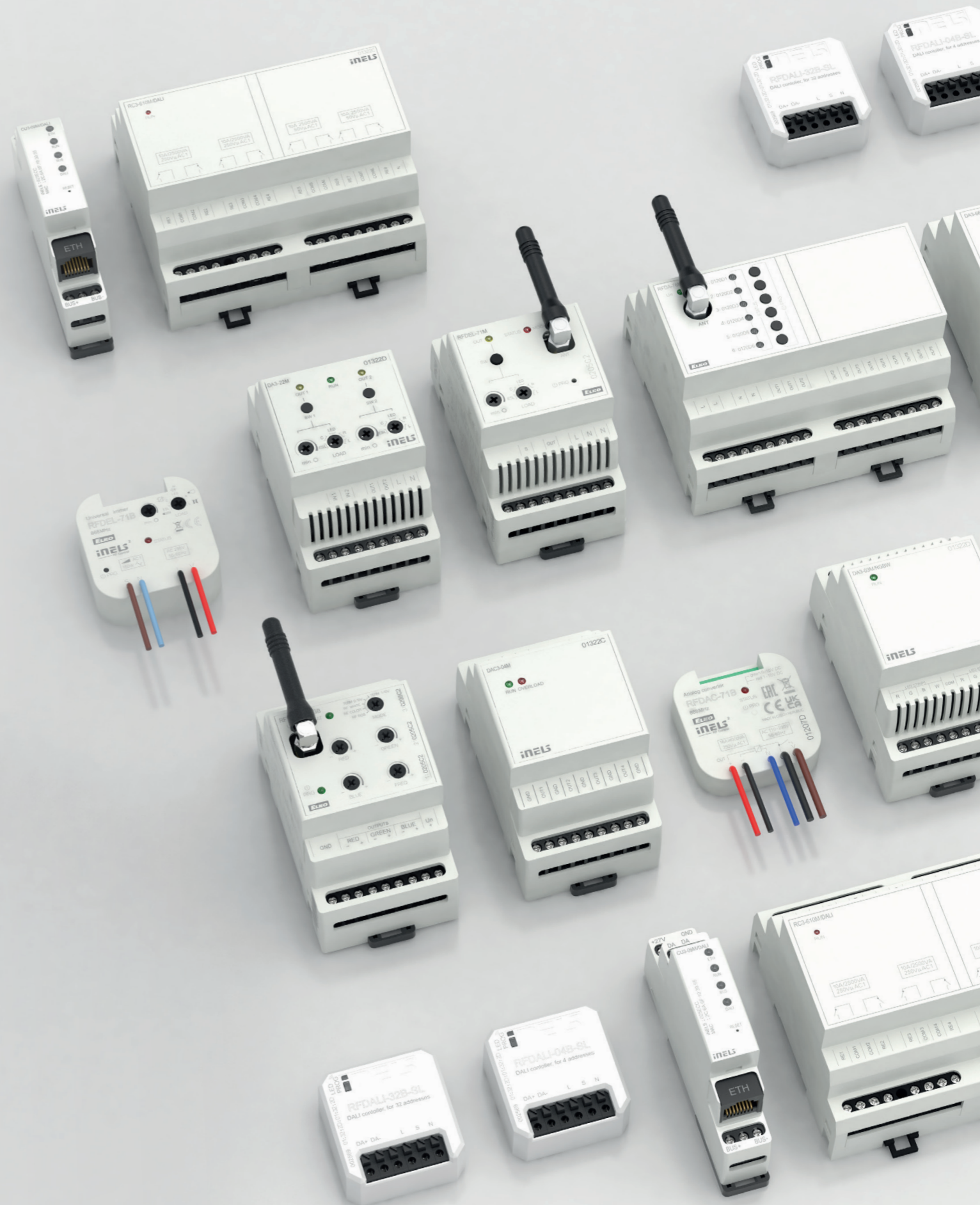

Detectors

Automate Every Space

Enhance your lighting control with iNELS sensors, seamlessly integrating security, automation, and efficiency. From wireless motion detectors to BUS-integrated PIR and light sensors, achieve precise, energy-efficient control.

A Detectors



RFWD-100
Window/Door detector for seamless security and automation.



RFMD-100 / RFMD-200
Motion detectors with precision sensing for lighting control.



PMS3-01
Compact PIR motion detector for accurate presence detection



MCD3-01
Ultra-slim microwave motion detector for discreet yet powerful performance.

B Light sensors



DLS3-1
Light intensity sensor for optimized lighting based on environmental brightness.



RFSOU-1
Twilight switch for automatic lighting based on ambient light levels.



Combine sensors to the lighting control to create smarter and more efficient lighting systems.

Controllers

Any Design Available

Control lighting effortlessly with iNELS products, including Classic, Glass, and Metal options. Enjoy touch panels, motion automation, and customizable switches for efficiency and comfort. Personalize controllers at icons.inels.com for a touch of luxury.



A Nature Frame



On-wall button controllers

iNELS offers on-wall button controllers for lighting control, compatible with switches and dimmers. Available in stylish LOGUS90 frames (plastic, glass, wood, metal, stone) with wired and wireless options.

B Glass

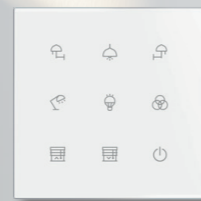

Glass touch controllers

iNELS glass touch controllers (wired and wireless) offer elegant black/white designs with capacitive buttons for lighting, dimming, and scene control. They include temperature sensors, customizable macros, and external device connectivity.

A Acrylic



Glass button - Flexibility and Control in One

Glass switch buttons (4, 6, or 9 buttons) feature customizable functions, integrated temperature sensors, external connectivity, white illumination, and elegant black/white designs for unparalleled style and luxury.

B Metal

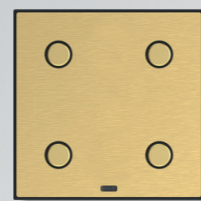

Metal Controllers: Redefining Style and Luxury

Metal switch buttons (4, 6, or 9 buttons) offer customizable functions, temperature sensors, external connectivity, white illumination, and premium finishes (copper, brass, silver, black) for advanced automation.

Touch units

Smart and Versatile

The INS4SQ, INS8SQ, and INS10SQ touch controllers deliver seamless lighting control, scene creation, and automation. With high-resolution displays, temperature and humidity sensors, and support for RS485, Modbus, and VRF, they are PoE-powered for efficient operation, ensuring comfort and energy savings.

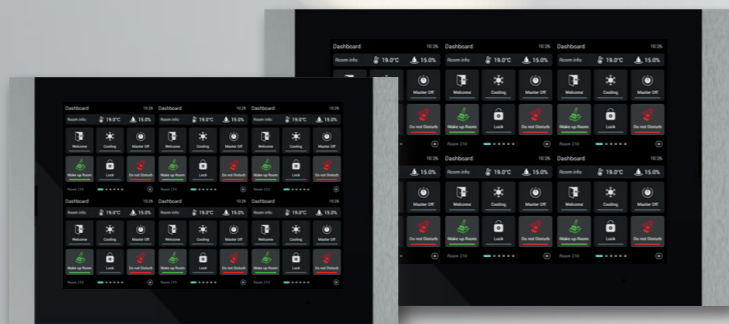

INS4SQ, INS8SQ, INS10SQ

The INS4SQ, INS8SQ, and INS10SQ touch controllers deliver seamless lighting control, scene creation, and automation. With high-resolution displays, temperature and humidity sensors, and support for add-on protocols like KNX, Modbus, Zigbee, INELS, MQTT and VRF, they are PoE-powered for efficient operation, ensuring comfort and energy savings.

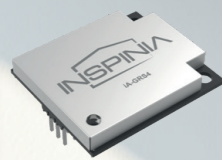

Order Code:	A-GRS4
Supported Media:	RS485
Power Consumption on Bus:	None
Isolation Type:	Board-to-board Galvanic Isolated
Dimensions:	35x30 mm

ADD-ONS

Add-ons enhance the functionality of EST touch panels by providing additional connectivity options. Examples include modules for INELS, KNX, RS485, HVAC systems, lighting systems, and other wired and wireless protocols.



Order Code:	A-ZGB
Supported Media:	Zigbee
Power Consumption on Bus:	None
Isolation Type:	None
Dimensions:	35x30 mm



Order Code:	A-KNX
Supported Media:	KNX TP
Power Consumption on Bus:	None
Isolation Type:	None
Dimensions:	35x30 mm

Gateways

Small but Powerful

iNELS gateways bring unparalleled flexibility and intelligence to lighting control, offering solutions for both wired and wireless installations. Whether you're designing a home, office, or commercial space, our gateways deliver advanced automation and seamless integration to meet all your lighting needs.

Advanced Automation, Scenes, and Schedules

Create personalized lighting scenes and schedules for any occasion, ensuring comfort and efficiency at all times.

Human-Centric Lighting and Mood Settings

Enhance well-being and productivity with lighting that adapts to your daily rhythms and mood preferences.

Supports All Types of Lighting Loads

From dimmable LEDs to complex lighting arrays, iNELS gateways manage every type of lighting load with precision.

Cloud Connectivity and App Control

Remotely control and monitor your lighting from anywhere via the iNELS Cloud or the intuitive mobile app.

Voice Control with Alexa and Google

Integrate effortlessly with Amazon Alexa or Google Assistant for hands-free control.

MQTT for Third-Party Integration

Enjoy robust compatibility with third-party systems, thanks to support for the MQTT protocol.



eLAN-103 & eLAN-204 box

The eLAN Smart Wireless gateways of lighting and devices in smart homes and buildings. It supports automation rules, scene creation, and time scheduling, ensuring efficient operation based on triggers like motion or schedules.

With the iNELS app, users can control devices remotely and integrate with voice assistants like Google Home and Alexa for hands-free operation. The eLAN gateway is an essential tool for building smart, automated environments.

Central unit CU3-09M

The CU3-09M is a key component of iNELS BUS installations, offering advanced features like automation, scene creation, and time scheduling. Equipped with a DALI bus, it controls up to 64 DALI devices for seamless lighting integration.

Supporting MQTT and Ethernet connectivity, the unit enables real-time app and cloud-based control, remote access, and third-party system integration. The CU3-09M centralizes control, enhances scalability, and simplifies smart environment management.



Use cases

Motion-Based Control

Motion-based control uses presence detection to adjust lighting automatically based on occupancy. By activating lights only when needed, it reduces energy waste and adds convenience, ideal for spaces like hallways, offices, and parking areas.

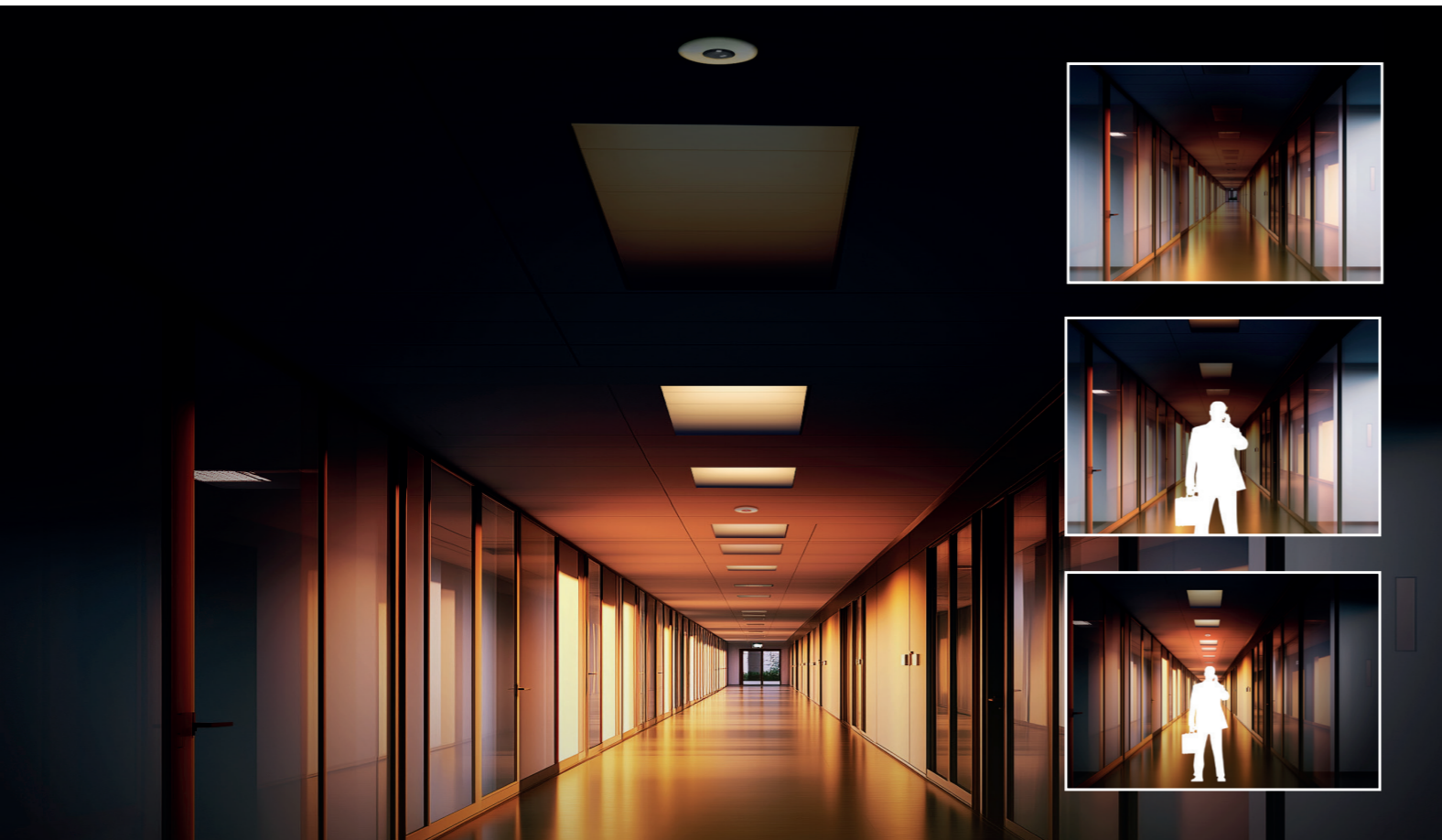

Energy Savings

By ensuring that lights are only on when spaces are occupied, motion-based control reduces unnecessary energy consumption. This approach lowers energy bills and contributes to a sustainable environment.



Enhanced Automation

With presence detection technology, motion-based systems create a fully automated lighting experience, eliminating the need for manual intervention. Lights turn on automatically when someone enters a room and turn off after a specified period of inactivity.



Extended Lamp Life

Reducing the duration that lights remain on helps extend the lifespan of lighting fixtures, decreasing replacement and maintenance costs over time.



Improved Safety and Convenience

Automatic lighting ensures well-lit environments when needed, enhancing safety in areas such as stairways, parking garages, and hallways. Additionally, it offers hands-free operation, improving convenience for occupants.

Schemes:

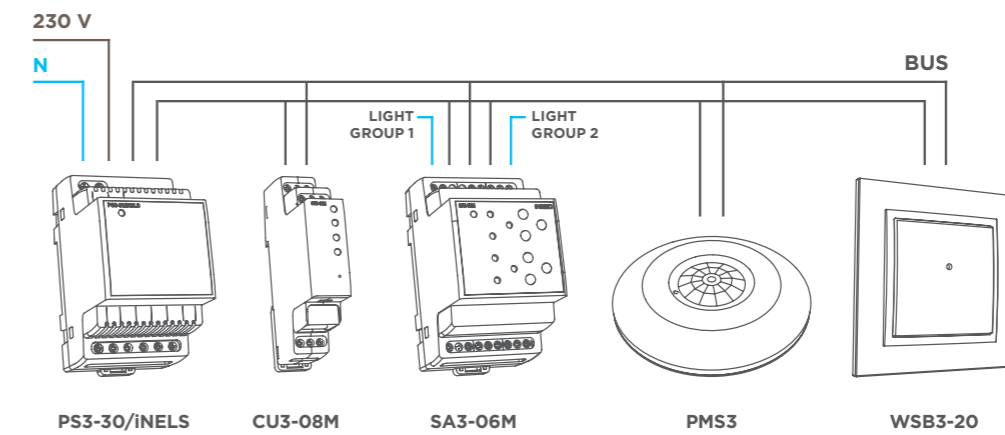
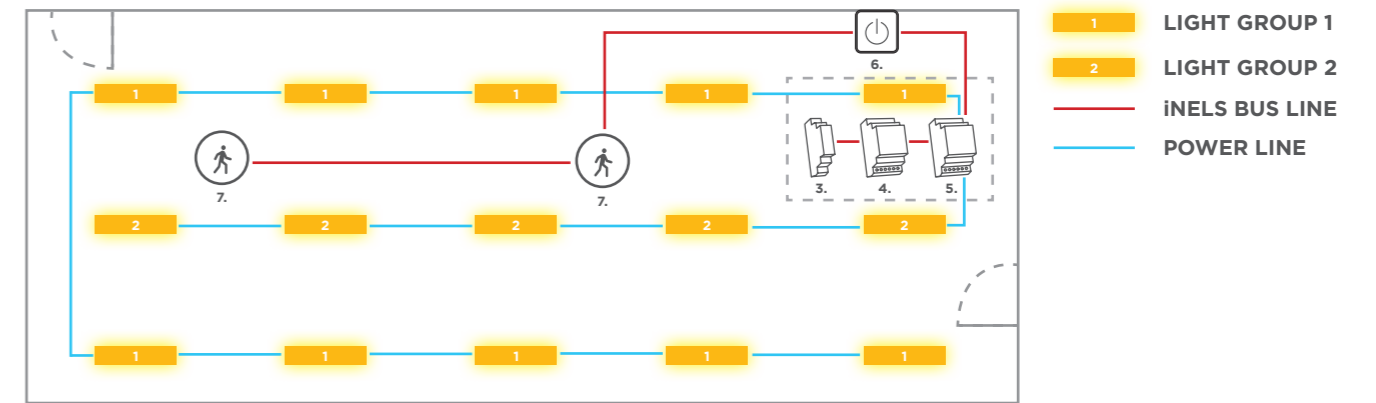

Units:



1. Central Unit (CU3-08M)

The CU3-08M central unit acts as the brain of the system, processing signals from connected sensors and controlling lighting circuits based on pre-configured logic. It has 2 bus to control 64 iNELS units. MQTT for 3rd party communication and iNELS cloud for remote control.



2. Power supply (PS3-30/iNELS)

The PS3-30/iNELS is a switched, stabilized power supply designed specifically for the iNELS BUS wiring system, providing a total power output of 30 W. It serves as a reliable power source for central units and external masters within the iNELS network, ensuring consistent operation of all connected devices.



3. On/Off Circuits (SA3-06M)

The SA3-06M module allows for direct control of lighting circuits. It receives instructions from the CU3-09M central unit and enables the on/off control of connected lighting fixtures based on motion sensor signals.



4. Motion sensor (PMS3)

This motion sensor detects occupancy within its designated range and sends a signal to the central unit to trigger lighting activation or deactivation. The PMS3 is ideal for standard room applications where precise motion detection is required.

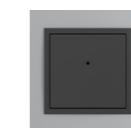

5. Manual Control (WSB3-20)

For added flexibility, the WSB3-20 provides manual control, allowing users to control lighting as needed. This controller works alongside the automated system, giving users control over specific lighting adjustments without disrupting the overall automation settings.

Use cases

Human Centric Lighting Control

Human Centric based control uses sensors to adjust artificial lighting based on ambient light, ensuring consistent illumination. This optimizes energy use, reduces eye strain, and enhances comfort in spaces like offices.

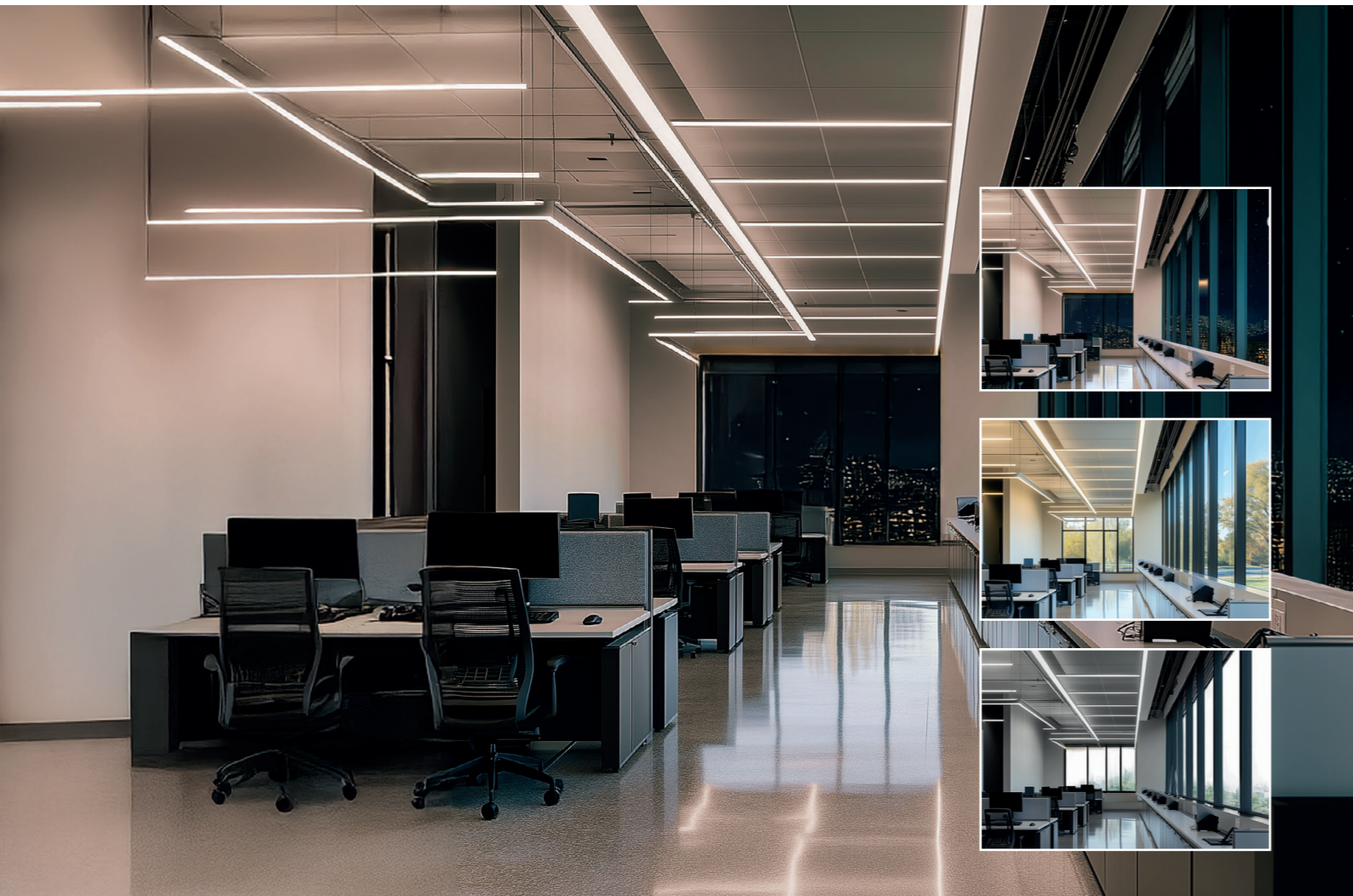

Energy Efficiency

By adjusting lighting based on ambient conditions, this control system reduces unnecessary energy use, leading to cost savings and environmental benefits.



Consistent Illumination Levels

The system maintains ideal light levels, improving comfort and reducing eye strain for occupants in office environments.



Enhanced Flexibility

The combination of automated intensity control with manual override options (via the GSB3-60SB) gives users flexibility, enabling them to adjust lighting to meet specific needs.

Schemes:

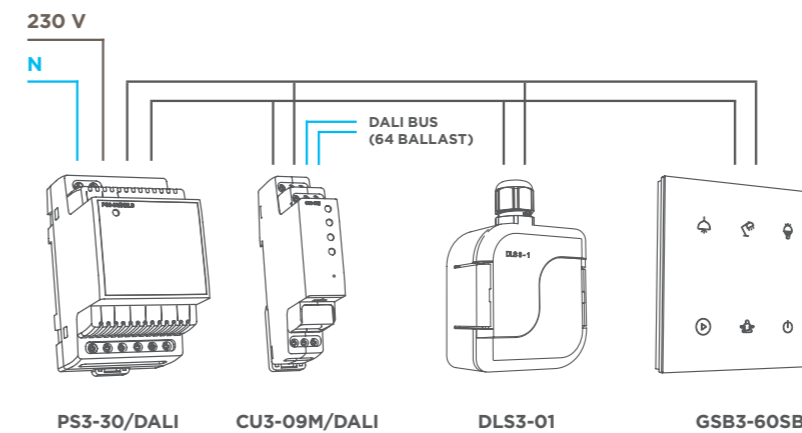
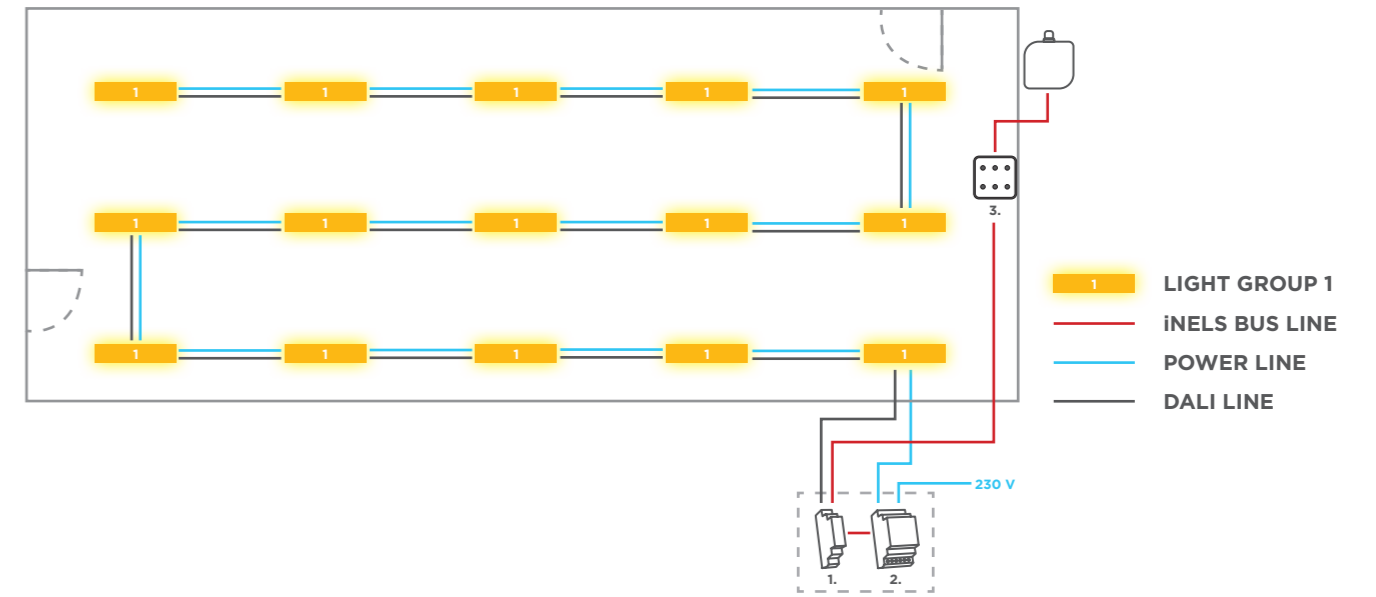

Units:



1. Central Unit (CU3-09M/DALI)

Acting as the control hub, the CU3-09M with DALI (Digital Addressable Lighting Interface) support processes input from ambient light sensors to adjust connected DALI-enabled lights in real time. This centralized unit allows precise control, ensuring each light operates at optimal brightness according to the detected ambient light levels.



3. DALI Power Supply (PS3-30/DALI)

The PS3-30/DALI power supply is essential for operating DALI-enabled lighting systems, providing stable power for all DALI components, including sensors, lights, and the central unit. This power supply supports consistent operation and helps maintain the integrity of the DALI communication network.



2. Ambient Light Sensor (DLS3-01)

The DLS3-1 sensor measures surrounding light levels and sends this data to the CU3-09M/DALI central unit. By continuously monitoring the ambient light, the DLS3-1 ensures that the system maintains the pre-set illumination levels, adjusting lighting smoothly as natural light changes throughout the day.

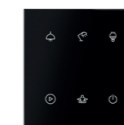

4. Manual Control Panel (GSB3-60SB)

For added flexibility, the GSB3-60SB provides manual control, allowing users to adjust lighting levels as needed. This switch panel works alongside the automated system, giving users control over specific lighting adjustments without disrupting the overall ambient control settings.

Use cases

Scheduled lighting solution

Time-based control uses scheduled lighting adjustments to optimize energy use in environments like offices, commercial spaces, and public buildings. By automating lighting based on schedules, it ensures lights are used only when needed, reducing waste and energy costs.



Schemes:

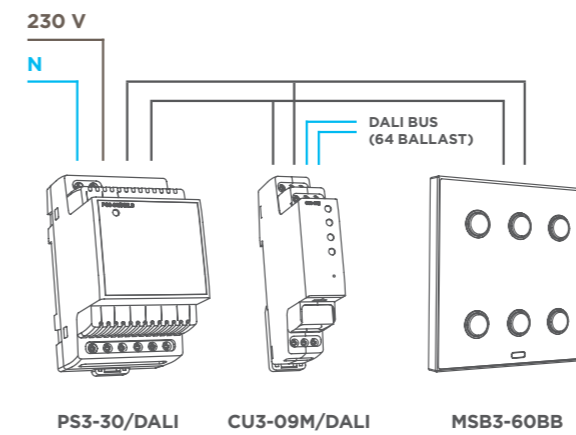
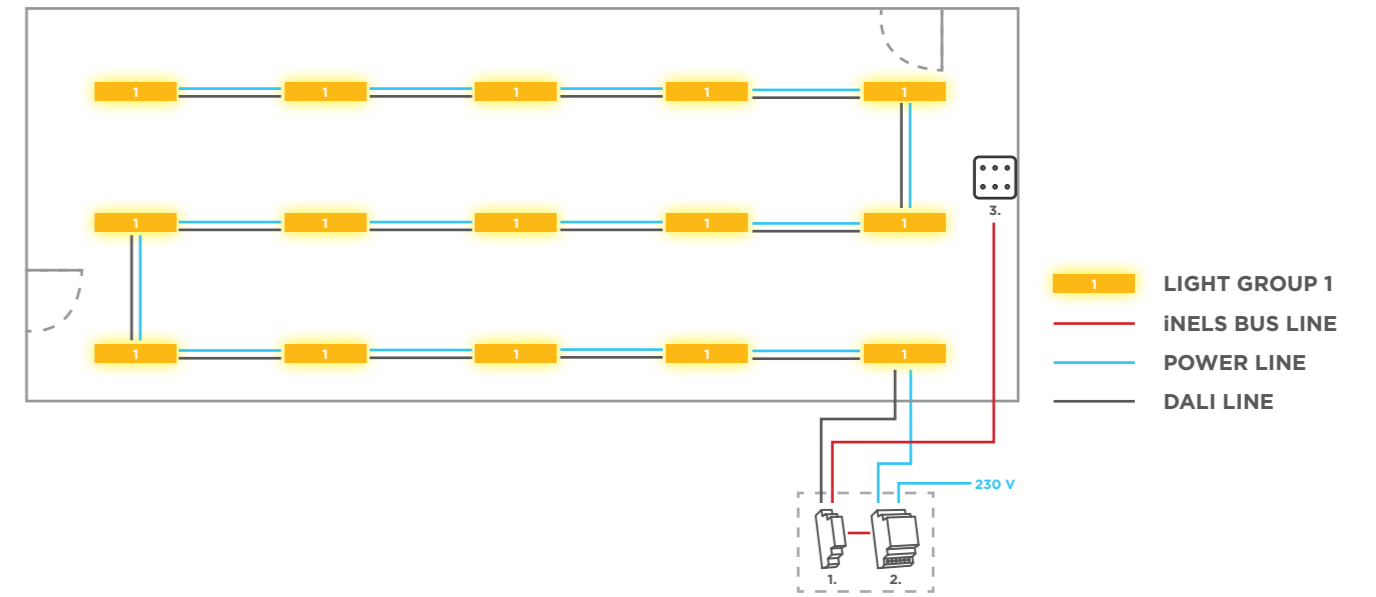

Units:



1. Central Unit (CU3-09M/DALI)

The CU3-09M/DALI stores time schedules and controls light groups on the DALI line, turning them on/off automatically based on set times. Multiple schedules can be programmed for different needs, ensuring lighting matches the building's operational hours.



2. Power supply (PS3-30/DALI)

The PS3-30/DALI power supply is essential for operating DALI-enabled lighting systems, providing stable power for all DALI components and iNELS BUS line including sensors, switching unit and the central unit.

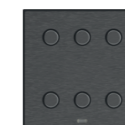

3. Manual Control Panel (MSB3-60BB)

The MSB3-60BB allows users to manually adjust light groups as needed, temporarily overriding scheduled lighting plans for flexibility.



Time Scheduling

Time schedules are set on the CU3-09M/DALI central unit to control specific lighting groups. Multiple schedules can be programmed to suit different times and areas, turning lights on or off as needed.



Automated Triggers

The CU3-09M/DALI triggers the DALI-controlled lights according to the scheduled times, automating lighting adjustments without manual intervention.



Manual Override

If needed, users can manually control light groups using the MSB3-60BB panel, overriding the time-based schedule temporarily for flexibility.



Automatic Reversion

After manual override, the system reverts to the programmed schedule at the next cycle, ensuring energy-efficient lighting control resumes as planned.

More than Technology

Design that fits your style

GSB3 - Glass switch buttons

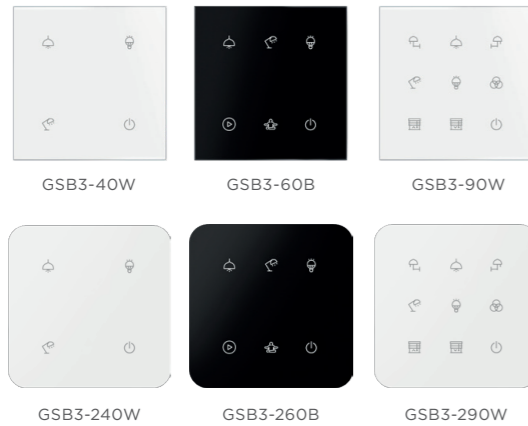

RFSW - Controller with output relays

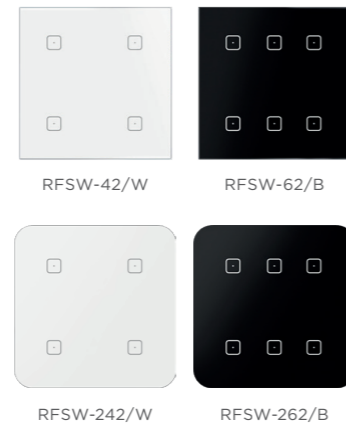

MSF3 - Socket frames



RFWB - On-wall button controllers

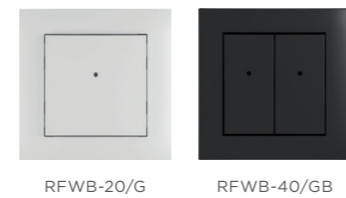

MSB3 - Metal switch buttons

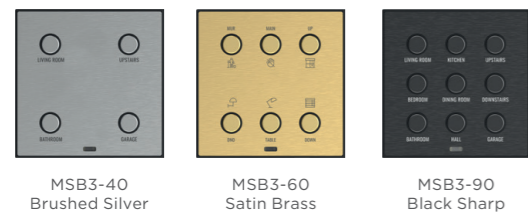

RFDW - Controller with dimmer

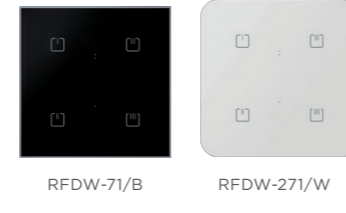

ZSB3 - Glass switch buttons



RFGB - Glass touch controllers



ZSB3 - Socket frames

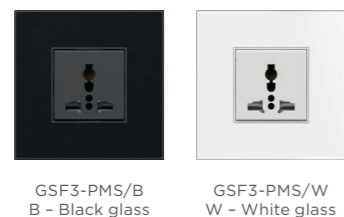

Online Customization

OEM - the best for the best

ELKO EP as a manufacturer has technologies that allow us to offer you a wide range of customization: colors of controls, shapes of glass, icons and button descriptions, including hotel room numbers and even hotel logos. Special and unusual combinations can be made on request.



We can supply the entire order with elements pre-programmed from the factory so that you only install them according to their codes in the correct room numbers. This will significantly reduce programming and commissioning costs.

You can easily customize the control elements to suit your needs on our website. Visit icons.inels.com and create your own design in just a few minutes.



Online customization:
icons.inels.com

Simple Steps to Smart Lighting

Setting up smart lighting doesn't have to be complicated. With the iNELS BUS system, you can easily manage lighting in your home or office to match your daily needs. Whether you're relaxing in the living room or creating a focused work environment, a few simple steps will open the door to the world of smart lighting. Get ready for energy savings, increased comfort, and lighting scenes tailored to every occasion.



2.

Step

Choose Your Spaces

Decide where you want to control lighting - living rooms, bedrooms, offices, or even outdoor areas. Every space can have customized lighting.



1.

Step

Pick Your Devices

Select the right combination of sensors, controllers, and lighting actuators to suit your needs.

3.

Step

Installation

iNELS products are easy to install by a certified professional, with minimal wiring and setup required.



4.

Step

Set Your Scenes

Use the iNELS app to create your lighting scenes - for movies, work, relaxation, or parties.



Seamless Integration

with iNELS lighting control system

The iNELS system delivers unmatched flexibility and efficiency for modern lighting control, integrating seamlessly with devices, protocols, and third-party systems. Designed for scalability and compatibility, it ensures smooth communication and a unified intelligent lighting solution.



Seamless Integration with Cloud, MQTT, and Voice Assistants

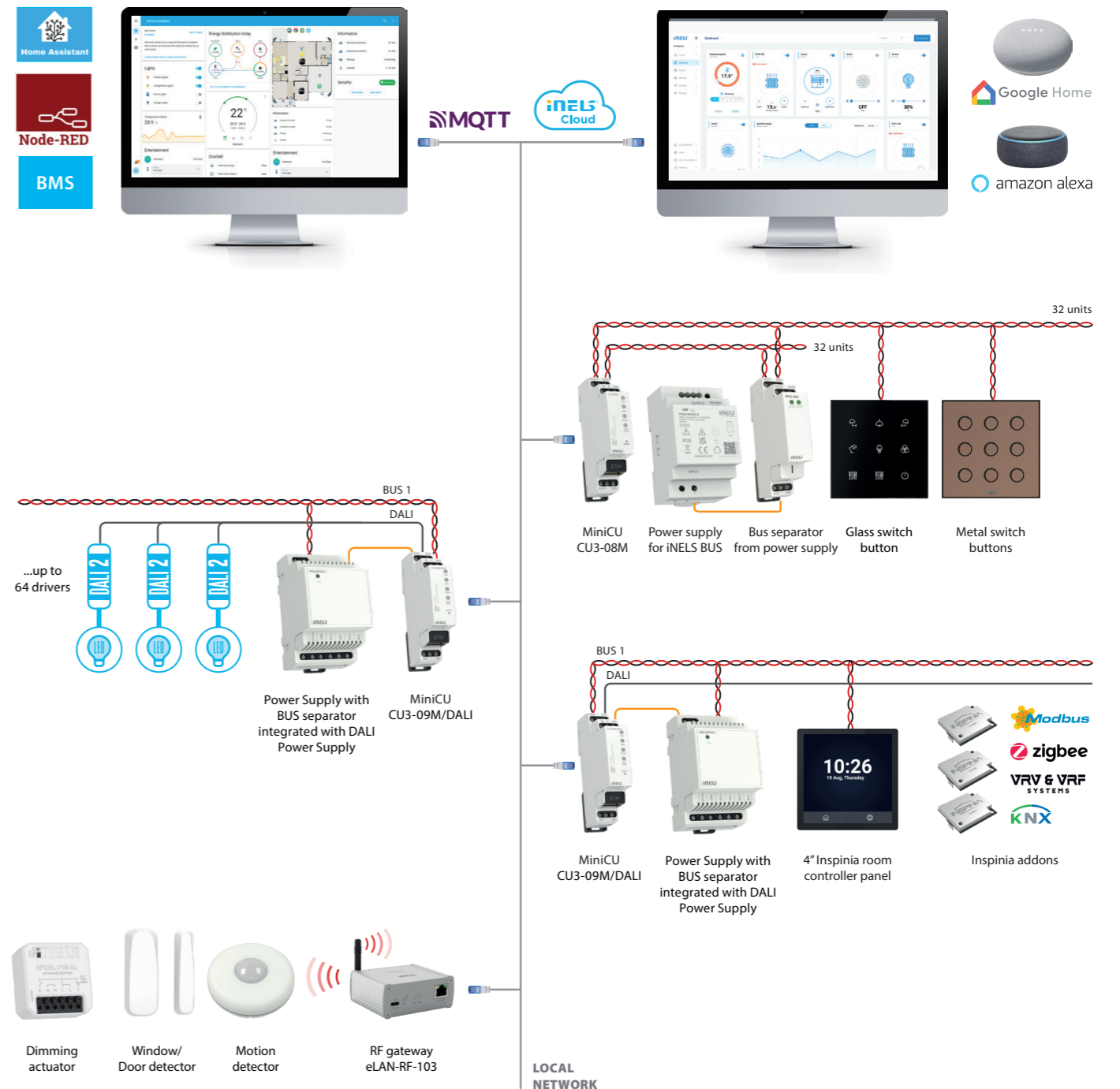

Multi-Protocol Support

iNELS system supports popular protocols like DALI, Modbus, and KNX, allowing easy integration with a wide range of lighting technologies.



Cloud Connectivity

Integrate with the iNELS Cloud for remote monitoring and control, enabling efficient management of lighting systems from anywhere.



BMS Compatibility

Effortlessly integrate with Building Management Systems (BMS) for centralized building control, ensuring optimized energy use and convenience over MQTT protocol.



Third-Party System Integration

Compatible with third-party devices such as voice assistants (Google, Alexa) and IoT platforms, offering enhanced user experience and automation.

Unlock the Future of Intelligent Lighting Control



ELKO EP, s.r.o. | Palackeho 493 | 769 01 Holesov, Vsetuly |
Czech Republic | phone: +420 573 514 221 | fax: +420 573 514 227 |
elko@elkoep.com | www.elkoep.com Published: 01/2025 | Modifications
or amendments reserved | © Copyright ELKO EP, s.r.o. | 1st edition